

Champion Sidecars

EZ-Steer Installation Guide

For

Harley Davidson FLH Motorcycles

Revision 8



Champion Motorcycle Accessories International, Inc.
Dba Champion Sidecars
11841 Monarch Street, CA 92841
(800) 875-0949 (714) 847-0949 Fax (714) 847-1539
www.championtrikes.com

FLH EZ Steer Instruction Supplement

Installation of the Champion EZ-Steer system is similar to the installation of the OEM triple clamp of your Harley Davidson FLH Motorcycle. We recommend that you use an OEM service manual and follow the prescribed disassembly, installation and torque specifications for the upper and lower clamp assembly.

Before Installing Kit (2008 & Prior)

The wiring bracket of the OEM upper triple clamp needs to be modified to fit the Champion upper triple clamp. After removing / disassembling the OEM parts from your motorcycle, position the OEM wiring bracket onto the Champion upper clamp as shown. Scribe the ID of the steering stem hole onto the wiring bracket and enlarge the hole to scribe line. This will allow the wiring bracket to fit over the new Stem Lock-Nut. Install OEM handle bar mount assemblies to Champion upper clamp using Item #5 (Handle Bar Mount Spacer). The spacers are used on top of the upper clamp.

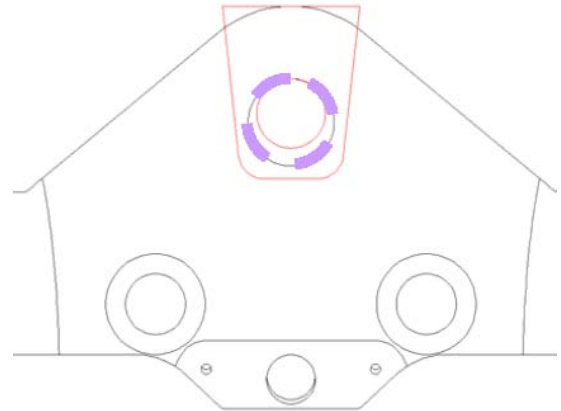

Installation Notes

- **Be sure to use the correct fork extension. Yellow 2002 and newer (non adjustable air pressure). Black for 2001 and older (adjustable air pressure). Be sure to double check the fork cap (Fork Tube Plug) being removed.**
- Reinstall the OEM O-rings on Item #7 (Fork Extensions) prior to installing in the fork tubes.
- On some of the Road King models with chrome headlight Nacelle, Item #9 must be mounted underneath upper clamp Item #2 to ensure enough room for air fittings.
- Be sure to replace fork covers in proper order, during installation of the fork tubes.
- Thoroughly clean sides of steering neck and install self adhering rubber stops where steering stop screws contact frame.
- Secure wires and cables clear of steering stop bolts.
- Do not torque Item # 1 (½-20 x 1-1/4" Hex Head Bolt) until fork tubes have been installed to assembly.
- Note the torque specification for the items listed in the table below.

Item #	Part Description	Torque Spec (Lb. Ft.)
1	½-20 x 1-1/4" Hex Head Bolt	50
8	Stem Lock Nut	35
15	M8 x 1.25 x 30 Socket Head Cap Screw (x4)	25

EZ-Steer Maintenance

The bearings in your EZ-Steer rake kit are normal wear items, not subject to replacement under Champion's one year Limited Warranty for the product. Failure to follow your motorcycle manufacturer's recommendations for periodic OEM triple-tree maintenance will accelerate the wear on these bearings. Checking/adjustment of the steering stem nut torque with the front end lifted, in accordance with your motorcycle manufacturer's recommendations, is important to reliable bearing service.